

KAWAI



U P R I G H T P I A N O S

A detailed close-up photograph of a piano's internal action mechanism. The image shows the hammer flippers, which are small wooden components that control the hammer's movement. The strings are visible, and the overall structure is made of wood and metal. The lighting is soft, highlighting the intricate details of the instrument's construction. A semi-transparent white banner is overlaid across the middle of the image, containing the text "NEXT GENERATION PIANO".

NEXT GENERATION PIANO

Kawai Upright Pianos

For over forty years, Kawai has been the architect of the modern piano, boldly pioneering the use of state-of-the-art materials and ideas to advance the piano art form.

While our nine decades of experience and tradition have enabled the creation of remarkable touch and tone for today, it is our celebrated technology that powerfully preserves and sustains that outstanding touch and tone for tomorrow. This innovative spirit is the essence of Kawai—and the principal reason why we remain a generation ahead in providing exceptional performance that endures.



OPTIMUM TOUCH

Touch is the quintessential key to joy, inspiration and artistry. Precise, consistent touch is the hallmark of every Kawai piano.

The Power of Pianissimo

One of the most coveted attributes of a fine piano is dynamic range—the ability to play not only thundering fortissimos, but also the most delicate and sensitive pianissimos. The technological superiority of the Millennium III Upright Action is most evident in its extraordinary ability to produce the perfect pianissimo. It is ironic that K Series technology speaks loudest when it whispers. The revolutionary Millennium III Upright Action is the secret behind the ultra-responsive touch of the K Series Professional Upright Pianos.

Extended key length & NEOTEX™ Key Surfaces

(K-500 K-600 K-700 and K-800 only)

Longer keys make playing easier and provide a more even response from the front to the back of the playing surface.

Our exclusive NEOTEX key surface material made with cellulose fiber offers the smooth, understated texture of natural ivory and ebony—and a semi-porous, silica-filled surface to absorb the hand's natural oils and perspiration that can cause slipping. NEOTEX resists cracking and fading over years of use and is used for both the sharps and the naturals for a consistent feel across the entire keyboard.





Dual-Beam Aluminum HAMMER Rail

The action rail is the “spine” of the piano’s action. K Series action rails are made of durable extruded aluminum with our advanced Dual-Beam design for strength and stability.

Die-Cast Aluminum Action Brackets

Made from a custom mold, die-cast parts are formed exactly the same every time. The K Series pianos feature three aluminum action brackets that are die-cast to provide an added measure of strength, uniformity and stability for accurate touch over time.



Millennium III Upright Action

Millennium III Upright Action features components made of ABS-Carbon, a composite material created by the infusion of carbon fiber into our renowned ABS Styran. ABS-Carbon is incredibly sturdy and rigid, which allows the creation of action parts that are lighter without sacrificing strength. The result is a stronger, faster action that offers more power, better control and greater stability than conventional all-wood actions.



ABS Carbon flange & Serrated rail surface

The action rail surface is finely serrated in three strategic area to secure the hammer, wippen and damper flanges in places for optimum action alignment and a more precise hammer strike.



ABS-carbon action parts

The use of ABS-Carbon makes the action parts tremendously strong and consistent. ABS-Carbon is many times stronger than wood and is virtually impervious to shrinking and swelling due to humidity. This extraordinary combination of strength and stability allows ABS-Carbon action parts to transfer energy to the hammers with unparalleled efficiency, power, precision and nuance for a superb playing experience.



PLEASANT SOUNDS

SOUND

Tradition and technology are indispensable elements of piano tone. Tradition lays the foundation for our distinctive tonal character. Technology empowers it with life, breadth, and depth that lasts from generation to generation.

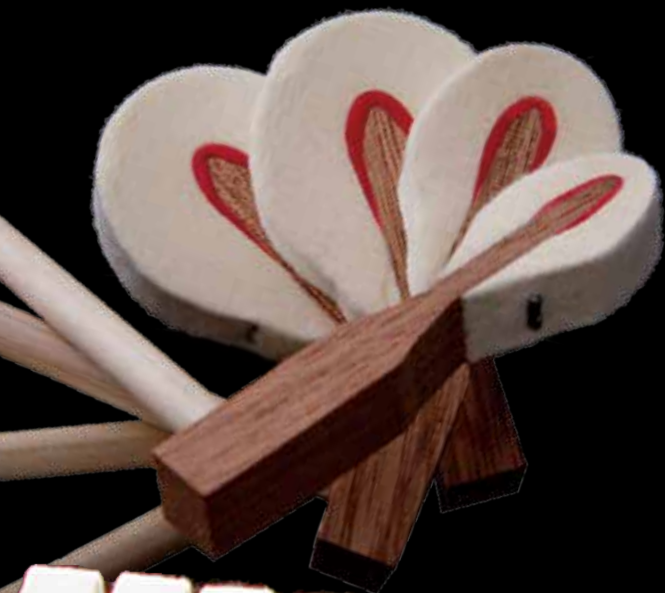

Mahogany wood core & T-stapled, double felted hammers

Mahogany hammer mouldings are lightweight and extremely responsive. Found on only the finest pianos, mahogany is used for the hammer mouldings on the entire line of K Series Professional Upright Pianos. All K Series hammers are T-Stapled to preserve hammer shape and fitted with an added interior layer of underfelt to support the creation of exceptional tone.

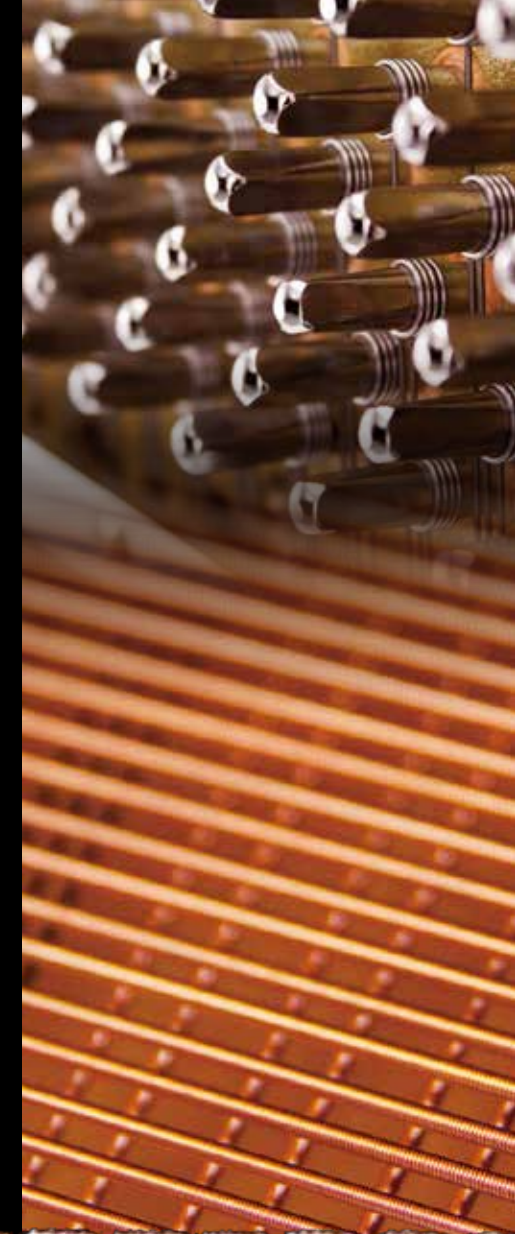
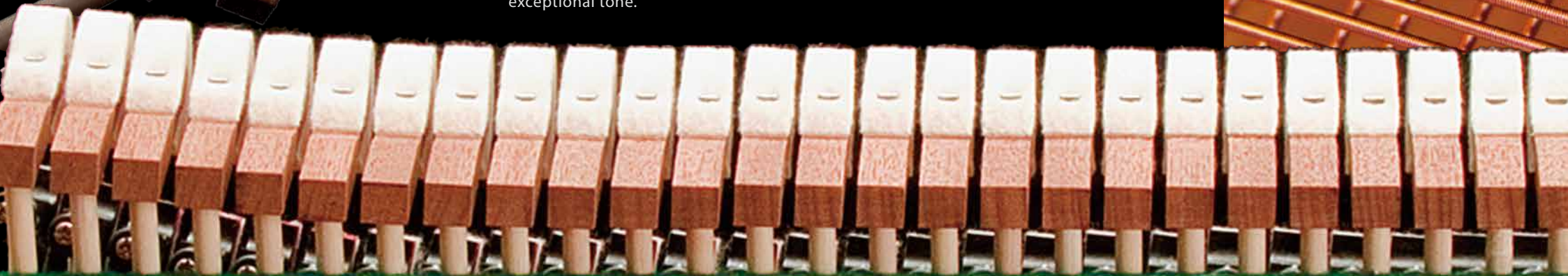

Tuning Pins

K Series tuning pins are made from the finest steel, machine-threaded for maximum bi-directional torque and nickel plated to enhance beauty and provide long-term protection.

Energy-Reflecting Contour Bars

Contour Bars reshape the speaking area of the soundboard to resemble the contour of a grand piano soundboard while reflecting sound energy back into the center for increased tonal power and sustain.



Strong, Balanced Back Assembly

K Series pianos are designed with tremendous strength to ensure stability of tone and touch over time. On all K Series models, the soundboard is supported by exceptionally strong multi-laminated back posts and our proprietary "matched strength" iron plate. This philosophy ensures a sturdy, well-balanced back assembly that supports string tension and provides a solid foundation for outstanding tone.



Tapered Soundboard made of Solid Spruce

The soundboard is the heart of a piano. Its purpose is to transform the vibrations of the piano's strings into a rich, resonating tone. Kawai uses only straightgrained, quarter-sawn solid spruce for K Series soundboards. Each soundboard is strategically tapered to maximize its tone producing capability. Only those that meet or exceed our demanding quality standards are selected for use in our professional upright pianos.

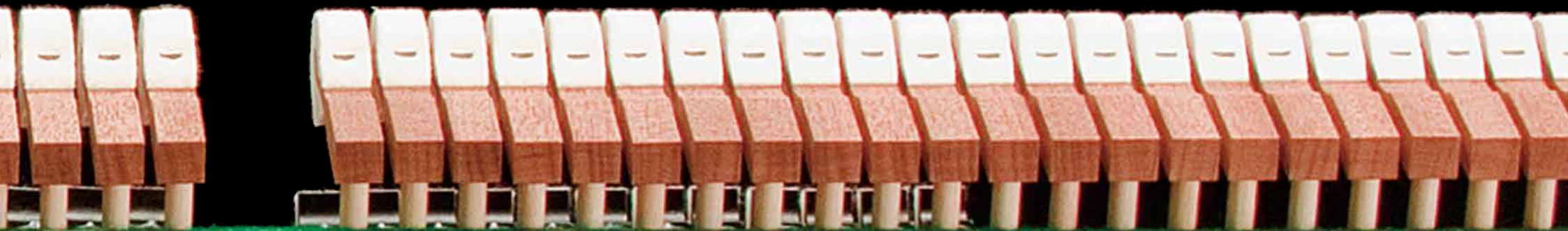

ATTRACTIVE CABINET STYLING

BEAUTY

The K Series pianos feature sleek lines and delicate accents that convey a striking, stately presence. By combining elegant form with rich, vibrant textures of tone, they will surely enhance the cultural ambiance of any room.



Cast Brass Pedals

Our proprietary casting process binds molten brass to a sturdy steel core resulting in strong, beautiful pedals that will not wear through over time.

Wide Music Rack

Conveniently built into the fallboard, the music rack on K-500, K-300 and K-200 extends nearly 1,000mm to accommodate multiple music books or sheet music that extends laterally.

Brass Front Casters

Front casters made of solid brass are as sturdy as they are attractive. Double casters are used for the larger K Series models



The Eternal Beauty of an Upright Piano

Modern design shines in space. A design that was born from the fusion of new ideas and modern technology, and assembled with the highest accuracy. With its square form and dynamic lines, the K series has a simple yet certain personality, in which we meet beauty for the first time.

Soft-Fall Fallboard Closing System

The ultra-slow "Soft-Fall" closing system protects hands and the piano's finish from the harm that a jarring close might cause.





K-500



K-300

K-500 K-300 K-200

K-500 K-300 K-200 offers the dependability and character needed to please any performing pianist from the novice to the seasoned professional.



K-200

K-500

Height 130cm Width 150cm Depth 62cm Weight 238kg

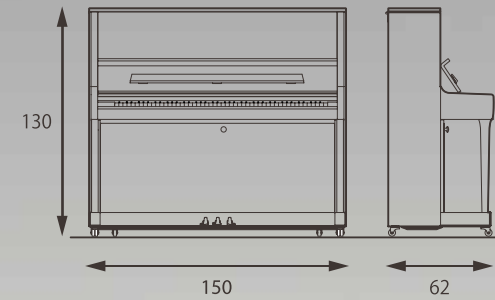

- Exclusive Millennium III Upright Action with ABS-Carbon Composites
- Duplex Scale (Fore)
The duplex scale enhances harmonics in the treble range, adding brilliance and richness to the piano's tone.
- NEOTEX™ Key Surfaces
- Double Felted, Mahogany Core Hammers

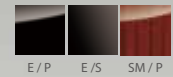

K-300

Height 122cm Width 149cm Depth 61cm Weight 227kg

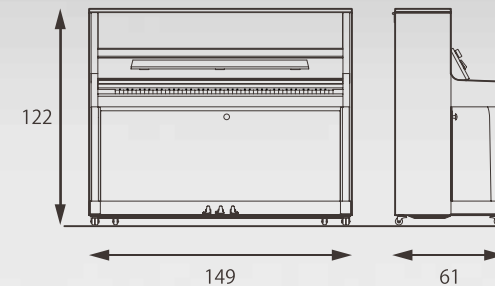

- Exclusive Millennium III Upright Action with ABS-Carbon Composites
- Double Felted, Mahogany Core Hammers

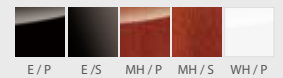

K-200

Height 114cm Width 149cm Depth 57cm Weight 208kg

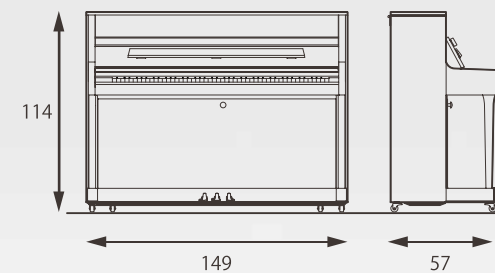

- Exclusive Millennium III Upright Action with ABS-Carbon Composites
- Double Felted, Mahogany Core Hammers

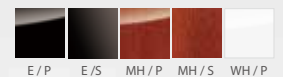



K-700

K-700 K-400

K-700 K-400 features a grand-style music rack that places music at eye level and provides a solid surface for sheet music and oversized music books.



K-400

K-700

Height 130cm Width 150cm Depth 62cm Weight 241kg

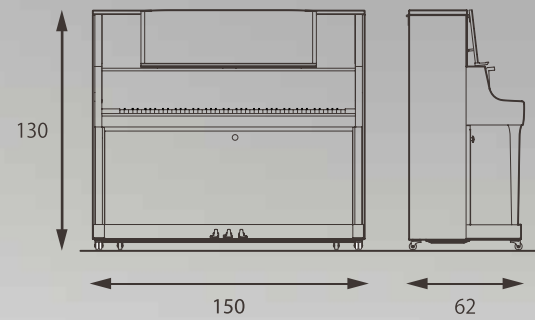

- Exclusive Millennium III Upright Action with ABS-Carbon Composites
- Duplex Scale (Fore)
The duplex scale enhances harmonics in the treble range, adding brilliance and richness to the piano's tone.
- NEOTEX™ Key Surfaces
- Double Felted, Mahogany Core Hammers
- Grand-Style "Hard Finish" Music Rack



K-400

Height 122cm Width 149cm Depth 61cm Weight 230kg

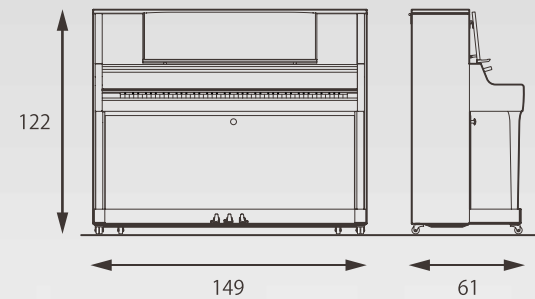

- Exclusive Millennium III Upright Action with ABS-Carbon Composites
- Double Felted, Mahogany Core Hammers
- Grand-Style Music Rack
- Dual-Hinged Fallboard





K-800

K-800 K-600

Its elegant form and exceptional tone will fulfill the needs of any professional teaching studio or intimate performance setting.





K-600

K-800

Height 134cm Width 153cm Depth 65cm Weight 284kg

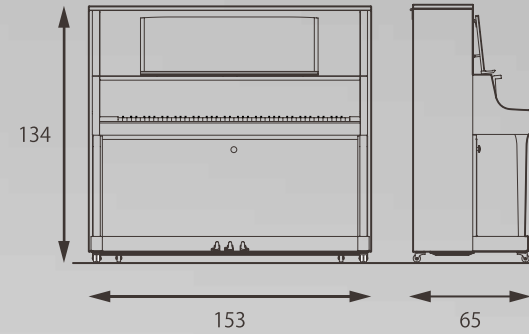

- Millennium III Upright Action with ABS Carbon Composites
- Agraffes
Agraffes ensure accuracy in string alignment, spacing and angles to produce greater uniformity, enhanced tone, smoother tuning and consistent "speaking length" for each note.
- Duplex Scale (Fore & Back)
- Grand-Style "Hard Finish" Music Rack
- NEOTEX™ Key Surfaces
- Double Felted, Mahogany Core Hammers



K-600

Height 134cm Width 153cm Depth 65cm Weight 280kg

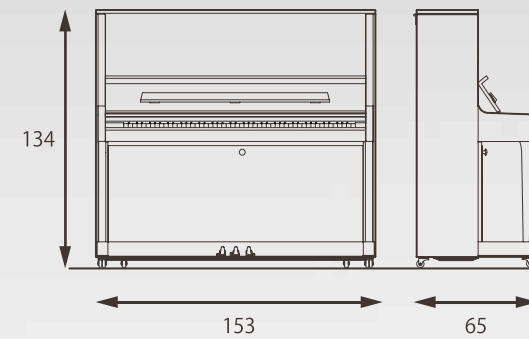

- Millennium III Upright Action with ABS Carbon Composites
- Agraffes
- Duplex Scale (Fore & Back)
- NEOTEX™ Key Surfaces
- Double Felted, Mahogany Core Hammers





Sapele Mahogany Polish

For K-500



Mahogany Polish

For K-200 and K-300



Mahogany Satin

For K-200 and K-300



Ebony Satin

For K-200 , K-300 and K-500



White Polish

For K-200 and K-300

AVAILABLE FINISHES



KAWAI

SILVER HARDWARE



Availability of silver hardware models may vary depending on market area. Please contact your local KAWAI dealer for details.

HYBRID PIANO

ANYTIME X²

AnyTimeX2 instruments incorporate an acoustic muting feature with powerful digital audio components, allowing pianists to continue enjoying the distinctive feeling of a traditional piano more discreetly, without disturbing family members or neighbours.



The slide-out control panel discreetly placed below the keybed, provides convenient access to digital features without devaluing the piano's traditional appearance.



Digital operation greatly extends the capabilities of the AnyTimeX2 piano beyond that of a traditional acoustic instrument, with convenient transpose and tuning facilities, a metronome and song recorder, and a selection of high fidelity sounds suitable for various musical occasions.

ATX2	K-500* / K-300 / K-200
Sound Source	Harmonic Imaging™ XL (HI-XL), 88-key piano sampling
Polyphony	max. 256 notes
Internal Sounds	27 voices
Display	128 x 64 pixel LCD with backlight
Reverb	Types: Room, Lounge, Small Hall, Concert Hall, Live Hall, Cathedral Parameters: Reverb Depth, Reverb Time
Metronome	1/4, 2/4, 3/4, 4/4, 5/4, 3/8, 6/8, 7/8, 9/8, 12/8 + 100 drum rhythms
Recorder	10 song, 2 track recorder – approximately 90,000 note memory capacity
USB Functions	Play & Record MP3/WAV/MIDI, Load & Save Internal Song/User Memory, Save SMF Song, RenameFile, Delete File, format USB, Convert Song to Audio, Overdub Audio
Lesson Function	Finger exercises + Alfred or Burgmüller, Czerny, Beyer, and Bach lesson books **
Virtual Technician	Voicing, Damper Resonance/Noise, String Resonance, Key-off Effect (incl. Key-off Release), Fall-back Noise, Hammer Delay, Topboard, Decay Time, Soft Pedal Depth, User Touch Curve, Temperament, Key of Temperament, Stretch Tuning, Tuning, User Tuning, User Key Volume, Half-Pedal Adjust, Minimum Touch
Other Features	Dual/Split/Four Hands, Balance Adjust, Key/Song Transpose, Tone Control (incl. User EQ), Speaker*/Phones/Line Out Volume, Audio Recorder Gain, Wall EQ*, Damper Hold, LCD Contrast, User Memory, Factory Reset, Lower Octave Shift, Lower Pedal On/Off, Layer Octave Shift, Layer Dynamics, MIDI Channel, Send PGM#, Local Control, Transmit PGM#, Multi-timbral Mode, Channel Mute, Auto Power Off
Jacks	MIDI (IN/OUT), USB (to Device), LINE IN, LINE OUT, Headphones x 2



* ATX2 model with soundboard speaker also available.

** Depending on market area.





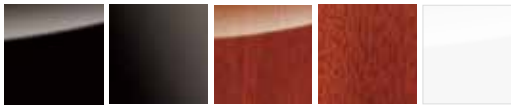

Headphones included with all AnyTime instruments.

SPECIFICATIONS

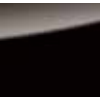

Model		K-200	K-300	K-400
Size	Height (cm)	114	122	122
	Width (cm)	149	149	149
	Depth (cm)	57	61	61
	Weight (kg)	208	227	230
Soundboard	Materials			
	Area (m2)	1.34	1.39	1.39
Back Posts		4	5	5
Cutoff Bar		1	2	2
Action				
Hammers	Felting			
	Materials			
Key Surfaces		Acrylic/Phenol	Acrylic/Phenol	Acrylic/Phenol
Speaking length of #1 string (mm)		1,157	1,200	1,200
Tuning Pins				
Duplex Scale		-	-	-
Agraffes		-	-	-
Front Casters		Single, Brass	Double, Brass	Double, Brass
Music Rack	Hard Finish	-	-	-
	Width of Music Rack (cm)	100	100	94
Lock		-	-	-
Available finishes				
<small>Availability of cabinet finishes may vary depending on market area. Please contact your local KAWAI dealer for details.</small>		<small>Ebony Polish Ebony Satin Mahogany Polish Mahogany Satin White Polish</small> <small>E / P E / S MH / P MH / S WH / P</small>	<small>Ebony Polish Ebony Satin Mahogany Polish Mahogany Satin White Polish</small> <small>E / P E / S MH / P MH / S WH / P</small>	<small>Ebony Polish</small> <small>E / P</small>



K-500	K-600	K-700	K-800
130	134	130	134
150	153	150	153
62	65	62	65
238	280	241	284
Solid Spruce, Tapered			
1.45	1.52	1.45	1.52
5	6	5	6
2	2	2	2
Millennium III			
All Underfelted			
Mahogany			
NEOTEX	NEOTEX	NEOTEX	NEOTEX
1,230	1,280	1,230	1,280
Nickel-plated			
Fore	Fore & Back	Fore	Fore & Back
-	1 - 51 key	-	1 - 51 key
Double, Brass	Double, Brass	Double, Brass	Double, Brass
-	-	○	○
100	100	94	105
○	○	○	○
 Ebony Polish E/P	 Ebony Satin E/S	 Sapele Mahogany Polish SM/P	 Ebony Polish E/P
		 Ebony Polish E/P	 Ebony Polish E/P

CARING FOR OUR WORLD

In 1997, Kawai's Ryuyo Grand Piano Factory became the first in the piano industry to receive ISO14001, the world's most prestigious certification for excellence in environmental management. At Ryuyo, work groups continuously monitor and improve emissions and waste control, green procurement, and a host of other energy conservation and environmental protection measures. The Kawai Forest Project has already planted over 285,500 seedlings. These vital efforts will continue to be a part of every piano we build. That is our promise to you—and to our world.



A FAMILY TRADITION

There is no more compelling reason to build an exceptional piano than one's own name on the instrument. For generations, the Kawai family has blended knowledge, skill, technology, and heart...in the quest to perfect the art of the piano.



KOICHI KAWAI
FOUNDER
(1886-1955)

INVENTIVE GENIUS,
MASTER BUILDER



SHIGERU KAWAI
(1922-2006)

PURSUED EXCELLENCE
AT KAWAI FOR OVER
FIFTY YEARS.



HIROTAKA KAWAI
PRESIDENT

CONTINUING THE PURSUIT
OF PERFECTION.

KAWAI
THE FUTURE OF THE PIANO

<http://www.kawai.co.jp/worldwide>